



- **Test-A-Pack quality and reliability**
- **Available in three sizes**
- **Quick disconnect pressure fittings**

---

### **Application:**

The F100-117X Test-A-Pack Package Test Chamber is used in conjunction with the F100-2700-1 Integrity Tester to test the integrity of non-porous, flexible packages. The transparent vacuum test chambers can be used with or without water to detect leakage in the package seal or material. Three sizes are available to accommodate a wide variety of products.

### **Features:**

Each chamber comes with a retainer designed to keep the unit under test completely submerged when water is added. By adding water to the chamber for submersion testing, the exact location of any package leak can be observed as a stream of bubbles. Our medium and large chambers also feature an internal fluid check valve to protect the integrity tester and pump from water contamination.

# SPECIFICATIONS

## Package Test Chamber Part Number: F100-117X

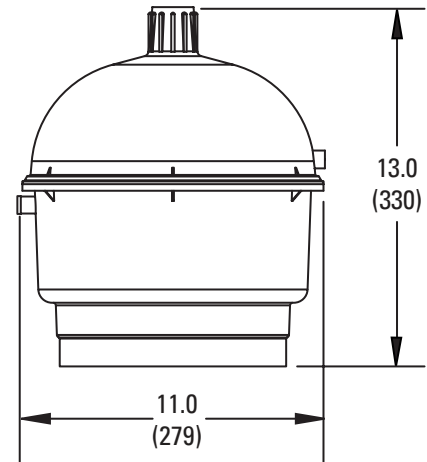
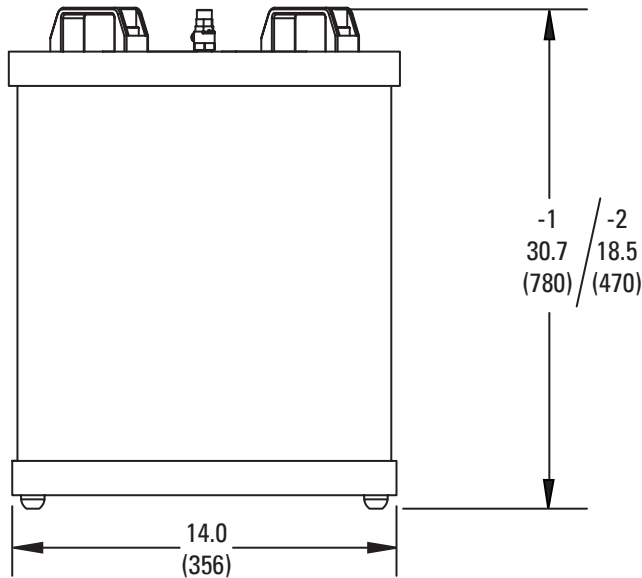

All dimensions in inch (mm)

### Ordering Information:

<b>Part Number</b>	F100-1175-1
<b>Description</b>	Small Package Test Chamber
<b>Relevant Dim.</b>	13.0" x 11.0"
<b>Weight</b>	3 lbs
<b>Application</b>	Packages up to 10.0" wide and up to 6.0" long
<b>Other Features</b>	Light weight polycarbonate chamber

### Ordering Information:

<b>Part Number</b>	F100-1177-1
<b>Description</b>	Large Package Test Chamber
<b>Relevant Dim.</b>	30.7" x 14.0"
<b>Weight</b>	35 lbs
<b>Application</b>	Packages up to 13.0" wide and up to 20.5" long
<b>Other Features</b>	Acrylic chamber, casters assembled to the base for ease of movement

### Ordering Information:

<b>Part Number</b>	F100-1177-2
<b>Description</b>	Medium Package Test Chamber
<b>Relevant Dim.</b>	18.5" x 14.0"
<b>Weight</b>	17 lbs
<b>Application</b>	Packages up to 13.0" wide and up to 10.5" long
<b>Other Features</b>	Acrylic chamber, rubber feet assembled to base for sturdy table top use