



- **Test-A-Pack quality and reliability**
- **Automatic operation**
- **Quick disconnect pressure fittings**
- **Package position stop**
- **Silicone jaws for test sample retention**

---

### ***Application:***

The F100-1600 Test-A-Pack Open Package Test Fixture provides an easy to use, stable platform for conducting pressurized seal strength testing on porous and non-porous flexible pouches and bags. Used in junction with Test-A-Pack's F100-2600 Seal Strength Tester, the Open Package Test Fixture is capable of testing a wide variety of packages with a maximum width of up to 24". Optional restraining plates are available for restrained package testing of pouches up to 14" wide by 20" long.

### ***Features:***

Test-A-Pack Open Package Test Fixtures are pneumatically actuated for fast clamping of the test sample. The clamping function is controlled by a hand operated, push button. Simply insert the open end of the sample over the inflation port between the silicone clamping jaws and press the button. Once clamped in place, the test sample is inflated with air supplied from the Test-A-Pack Seal Strength Tester. The sensing tube inside the inflation port provides feedback of the internal package pressure to the tester. When the test is complete, the clamping surfaces are released and the fixture is immediately ready to accept the next test sample.

# SPECIFICATIONS

## Open Package Test Fixture Part Number: F100-1600

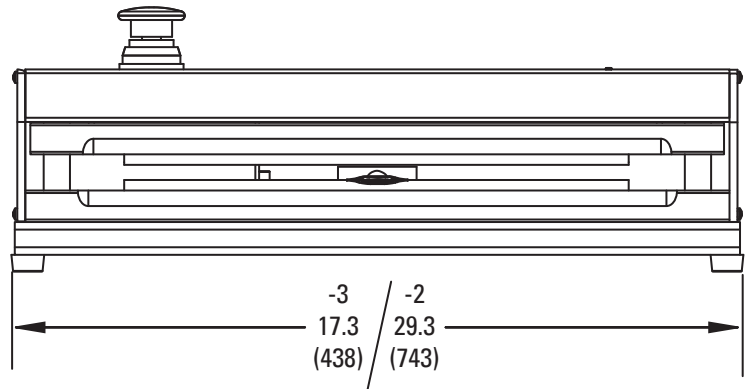
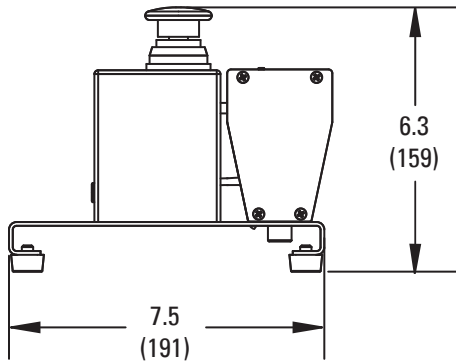

All dimensions in inch (mm)

### Ordering Information:

<b>Part Number</b>	F100-1600-2
<b>Description</b>	24" Open package test fixture
<b>Relevant Dim.</b>	29.25" x 7.5"
<b>Weight</b>	23 lbs
<b>Application</b>	Open bags up to 24" wide

### Ordering Information:

<b>Part Number</b>	F100-1600-3
<b>Description</b>	12" Open package test fixture
<b>Relevant Dim.</b>	17.25" x 7.5"
<b>Weight</b>	16 lbs
<b>Application</b>	Open bags up to 12" wide