



- **Test-A-Pack quality and reliability**
- **Adjustable probe height**
- **Quick disconnect pressure fittings**
- **Interchangeable test probes**

---

### **Application:**

The F100-1320 Test-A-Pack Closed Package Test Fixture provides an easy to use, stable platform for conducting pressurized seal strength testing on fully sealed flexible packages and lidded trays. Used in conjunction with Test-A-Pack's F100-2600 Seal Strength Tester, the Closed Package Test Fixture is capable of testing a wide variety of porous and non-porous packages with a maximum height of 18".

### **Features:**

This Closed Package Test Fixture consists of a heavy gauge aluminum platform and a needle probe assembly. The probe is used to penetrate and inflate the test sample, while the integral sensing tube provides feedback of the package's internal pressure to the Seal Strength Tester. The patented design feature allows the Seal Strength Tester to compensate for any air leakage during the test, insuring accurate and consistent burst values.

Two needle probe assemblies are available. The 3/16" single needle probe is used for most large porous and non-porous packages. The double needle probe works well with smaller non-porous packages. Both probes are interchangeable, allowing the user to quickly and conveniently test a wide variety of packages.

# SPECIFICATIONS

## Closed Package Test Fixture Part Number: F100-1320

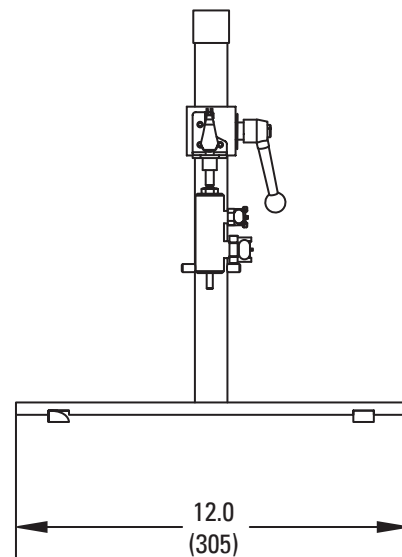
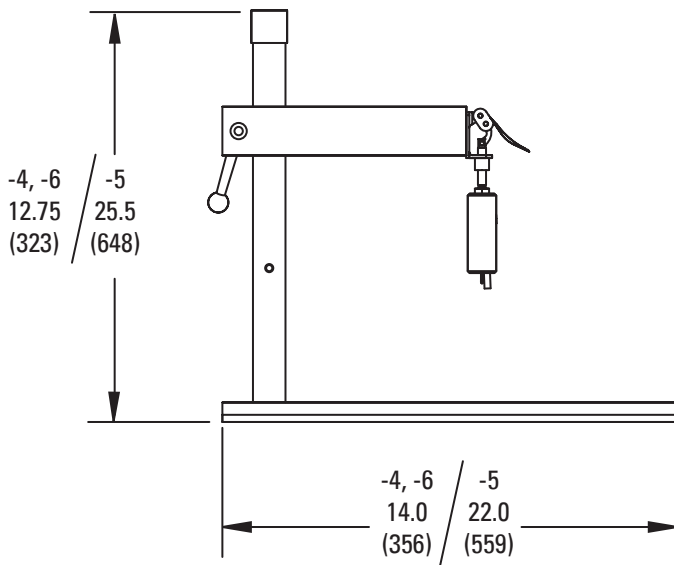

All dimensions in inch (mm)

### Ordering Information:

|                           |  |
|---------------------------|--|
| <b>Part Number</b>        | F100-1320-4  |
| <b>Description</b>        | Standard single needle closed package test fixture |
| <b>Relevant Dim.</b>      | 12.0" W x 14.0" L x 12.75" H                       |
| <b>Weight</b>             | 12 lbs   |
| <b>Application</b>        | Medium to large packages                           |
| <b>Max. Package Width</b> | 6.5" fully expanded                                |

### Ordering Information:

|                           |   |
|---------------------------|---|
| <b>Part Number</b>        | F100-1320-5                                     |
| <b>Description</b>        | Large single needle closed package test fixture |
| <b>Relevant Dim.</b>      | 12.0" W x 22.0" L x 25.5" H                     |
| <b>Weight</b>             | 18 lbs  |
| <b>Application</b>        | Large packages                                  |
| <b>Max. Package Width</b> | 18" fully expanded                              |

### Ordering Information:

|                           |  |
|---------------------------|--|
| <b>Part Number</b>        | F100-1320-6  |
| <b>Description</b>        | Standard double needle closed package test fixture |
| <b>Relevant Dim.</b>      | 12.0" W x 14.0" L x 12.75" H                       |
| <b>Weight</b>             | 12 lbs   |
| <b>Application</b>        | Small packages                                     |
| <b>Max. Package Width</b> | 6.5" fully expanded                                |