

### Emergency Flotation Valve and Cylinder Assembly



- **Compact**
- **Lightweight construction**
- **High Flow Capability**
- **Pyrotechnic Actuation**
- **Aircraft Qualified**

---

#### **Application:**

The Emergency Flotation System Valve and Cylinder Assembly is designed to rapidly inflate emergency flotation devices on military and commercial helicopters. Current applications include the Sikorsky SH-60 Seahawk and S-76 commercial helicopter. This system can also be applied to other cold gas inflation applications.

#### **Features:**

The system consists of a lightweight composite gas storage vessel and a valve manifold. Mounted to the valve manifold are a charging valve, pressure gauge, thermal relief device, over pressure protection burst disc and a pyrotechnic actuator (squib). The 490 cubic inch (8,030 cubic centimeters) composite bottle can be wrapped with Kevlar, Fiberglass or CFFC and may be charged with helium, nitrogen or air to 3,200 psig (220 bar).

The pyrotechnic device is fired with a 28 VDC, 5 amp all-fire signal causing the cutter to rupture the shear disc, initiating flow to the downstream system. The system is capable of inflating a 49 cubic foot (1.39 cubic meters) volume to 0.75 psi (0.05 bar) in four seconds at minimum operating temperature. The system flow rates may be sized to customer specific requirements.

System safety is assured by the shear disc, which provides over pressure protection by venting the pressure vessel at 4,250 psi (293 bar) and by a fusible plug which releases the gas if the assembly temperature exceeds 174°F (78.9°C).

# SPECIFICATIONS

## Valve and Cylinder Assembly Part Number: B13268-1

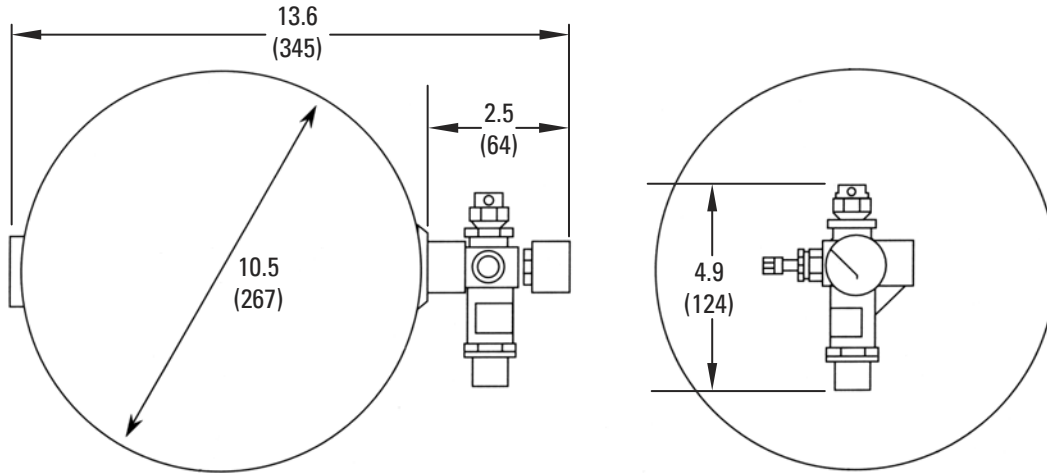

All dimensions in inch (mm)

### Specifications:

<b>Medium</b>	Helium, Nitrogen, or Air	
<b>Inlet Pressure</b>	3,200 psig	(220 bar)
<b>Relief Pressure</b>	4,484 psig	(309 bar)
<b>Proof Pressure</b>	5,000 psig	(345 bar)
<b>Burst Pressure</b>	6,667 psig	(460 bar)
<b>Flow Rate</b>		
<b>Helium</b>	51 cu ft in 4 sec	(1,444 L in 4 sec)
<b>Nitrogen</b>	51 cu ft in 8.5 sec	(1,444 L in 8.5 sec)
<b>Leakage</b>	0 at 3,000 psig (207 bar) 15 cc/min @ 0 to 5 psi	
<b>Weight</b>	6.8 lbs max	(3.1 kg)
<b>Volume</b>	490 cu in	
<b>Electrical Characteristics</b>		
<b>Voltage</b>	28 VDC	
<b>No Fire Current</b>	1.0 amp min	
<b>All Fire Current</b>	5.0 amp min	
<b>Case Resistance</b>	5 x 10 <sup>6</sup> ohm	

### Operating Environment:

<b>Temperature</b>	-30 to 120 deg F	(-34 to 49 deg C)
<b>Humidity</b>	0 to 90%	
<b>Mechanical Shock</b>	MIL-STD-810, Method 516.1 Procedure I, III and V	
<b>Vibration</b>	MIL-STD-810, Method 514.1 100-1000 Hz: .04 g <sup>2</sup> /Hz 1000-2000 Hz: -6dB/octave	

### Non-Operating Environment:

<b>Temperature</b>	-40 to 140 deg F	(-40 to 60 deg C)
<b>Salt Fog</b>	MIL-STD-810, Method 509.3 Procedure I	
<b>Sand and Dust</b>	MIL-STD-810, Method 510 Procedures I	
<b>Shelf Life</b>	5 years 5 years from first pressurization	