



- Complete subsystem
- High pressure Nitrogen
- Integrated regulator
- 900 to 1,500 psig regulated pressure

Application:

The GBU Manifold Assembly is a cold gas, pneumatic system that is used to control the movement of canard fins on Laser Guided Bombs (GBU-10, 12, and 16). The manifold assembly receives inputs from the guidance system and translates this data into fin movement by signaling the electro-mechanical solenoid valves to move. This allows the GBU to adjust its position while in flight and track to target.

Features:

The Carleton GBU Manifold Assembly consists of an accumulator, regulator, manifold and solenoid valves. This manifold assembly allows the customer to receive a fully tested subsystem that is ready to enter into production inventory. It features high pressure nitrogen cold gas storage system activated by pyrotechnic initiator. This pressure is regulated down by a regulator integrated into the manifold. Electro-mechanical solenoid valves control the flow of high pressure gas.

SPECIFICATIONS

GBU Manifold Assembly

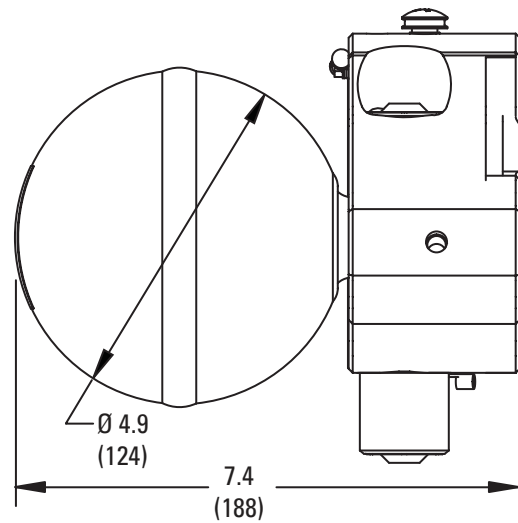
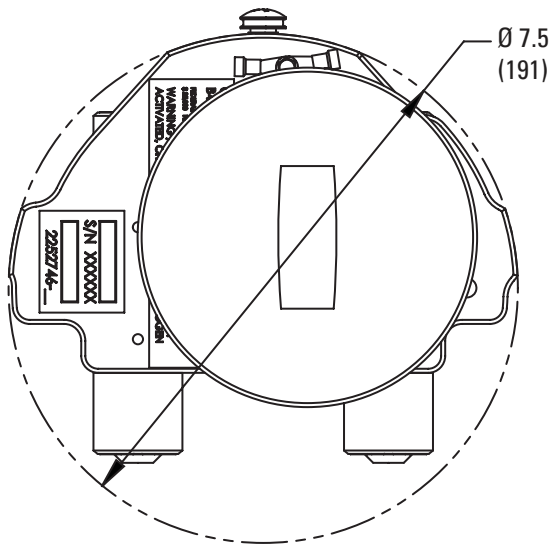

All dimensions in inch (mm)

Specifications:

Medium	Nitrogen	
Operating Pressure	8,000 psig	(552 bar)
Regulated Pressure	900 to 1,500 psig	(62 to 103 bar)
Proof Pressure	15,000 psig	(1,034 bar)
Burst Pressure	17,600 psig	(1,213 bar)
Weight	13 lbs	(5.9 kg)
Service Life	21 years	

Operating Environment:

Temperature	-67 to 185 deg F	(-55 to 85 deg C)
Humidity	0 to 100%	
Shock	25 g	
Vibration	13 Grms	

Non-Operating Environment:

Temperature	-85 to 185 deg F	(-65 to 85 deg C)
--------------------	------------------	-------------------

Product Interfaces:

Test Port	7/16 - 20 UNF
Connector	M24308/2-11F